

THERMODYNAMIC AND NO_x EMISSION ANALYSIS OF DIESEL ENGINE WITH INTAKE MANIFOLD STEAM INJECTION

Karlis Amatnieks, Ruslans Smigins, Aivars Birkavs

Latvia University of Life Sciences and Technologies, Latvia

k.amatnieks@outlook.com, ruslans.smigins@lbtu.lv, aivars.birkavs@lbtu.lv

Abstract. The steam injection method is an effective solution for thermal efficiency enhancement. While there exist different steam injection methods, only one of them is discussed in this paper presenting a thermodynamic analysis of steam injection in the intake manifold of a diesel engine to identify possible steam effects on the performance and combustion characteristics. The impact of steam injection mass on the thermodynamics of the diesel engine was evaluated by the engine model, which was created in the *ExtenSim7* software, including the relevant mathematical relationships. The engine *KDI 1903M* was chosen for analysis, and its technical characteristics were used to obtain the modelling data. As a result of the model operation, it is assumed that steam was injected into the intake manifold at the time of the induction stroke at different steam injection mass: 10, 20, 30, 40 and 50 mg. The model confirmed growth of the pressure increase ratio and effective power with the increase of the steam injection mass, as also variations in the temperatures at the end of compression and combustion. Some other important parameters, like NO_x emissions, are also discussed and compared using steam injection and without it. The results showed that at 50 mg of steam injection, the combustion temperature and NO_x emissions decreased by 36 K and 62 ppm, respectively. At the same time, a slight increase in power in the amount of 4.3% is observed due to a growth of the pressure increase ratio. The results provide guidance for the future experimental studies in laboratory conditions.

Keywords: diesel engine, steam, thermodynamic, model, analysis.

Introduction

For years, the internal combustion engine industry has been looking for a variety of solutions to reduce emissions following environmental regulations and restrictions. The range of such solutions included improvement of the combustion process in the engine and implementation of aftertreatment emission control technologies and the use of various fuel additives. In recent years, biodiesel additive to fossil diesel fuel has been actively used [1], which makes a significant contribution to the reduction of greenhouse gas emissions. Despite this, diesel engines are still considered as one of the largest contributors to environmental pollution caused by exhaust emissions, and this has stimulated researchers to look for other more efficient options, which include both hydrogen, hydroxyl gas and simply water injection. Hydrogen is one of the cleanest fuels due to its composition and combustion efficiency, but its usage is limited due to a lack of storage and supply facilities, as also safety operation in liquid forms due to a low temperature and high pressures. This could be solved by implementation of on-board hydrogen generation systems producing hydroxyl gas, which is produced by the water electrolysis process and is available in another form like hydrogen. Limitations to the use of all mentioned gaseous fuels in diesel engines are connected with the low cetane number of such fuels in a result of which gaseous fuels could be used in dual fuel mode or direct injection into the cylinder at the end of the compression stroke. Taking it into account numerous researches have been done with hydrogen [2], and also hydroxyl gas [3-4] addition to diesel fuel, biodiesel [5], diesel/biodiesel blends in such way improving the engine efficiency and also reducing emissions.

Water injection is another option, which has been widely used for similar purposes. Water injection improves atomization due to a very low interfacial tension between the fuel and water during the compression process, as also higher contact area results in a better mixing process of the air and fuel [6]. Additionally, the decrease in the peak flame temperature could reduce also NO_x emissions. Besides of these advantages it was observed that water inside the cylinder could pronounce corrosion. Therefore, steam injection was preferred as a more suitable method to avoid this negative effect.

The steam injection process is similar to that of water injection and is considered as one of technologies in waste heat recovery, as also a method to control emissions [7]. There exist different steam injection methods [8], which include pre-turbine steam injection (PTSI), intake manifold steam injection (IMSI), and in-cylinder steam injection (ICSI). The pre-turbine steam injection method allows to improve the turbine power and change the engine performance, while the intake manifold steam injection can reduce NO_x emissions due to a decrease of in-cylinder temperature by the impact of the

steam. Similarly, the ICSI method also leaves an impact on the engine emission characteristics due to an impact on the engine piston power, as also on increase in the exhaust pressure and mass flow rate. The number of studies conducted in this area is not large, but significant. Higher fuel reduction was observed with steam injection than that of water injection in case of in-cylinder injection for turbo compound diesel engine [7], while Parlak [9] has observed increase in the torque and power, as also decrease in NO_x emissions till 13% in all engine speeds using diesel fuel-canola oil methyl ester blends.

However, there exist some researches explaining the impact of steam injection using models. For example, Gonca [10] modelled the combustion process with a single cylinder, four-stroke, direct injection, naturally aspirated diesel engine fuelled with ethanol-diesel blend and confirmed decrease in NO_x emissions and improvement in the engine performance. Wu [11] reported improvement in the thermal efficiency by the steam injection temperature and injection mass, as also increase in the compression ratio of the in-cylinder steam-assisted cycle.

Literature review confirmed that theoretical researches including analysis of thermodynamics in case of diesel engines are limited and mainly are concentrated on the in-cylinder steam injection method. Therefore, this research is focussed on the intake manifold steam injection method and analysis of the main engine parameters including the in-cylinder pressure rise, temperatures at the end of compression and combustion, power and NO_x emissions. The aim is to understand whether the use of water steam and the increase in its concentration can affect the previously mentioned parameters.

Materials and methods

The impact of the steam injection mass on the thermodynamics of the compression ignition (CI) engine was evaluated by an engine model, which was created in the *ExtenSim7* software, including the relevant mathematical relationships. Since the construction diagram of the created model is too large to show in the given article, Fig. 1 represents the NO_x module of the model analyzed in this research. Initial conditions and assumptions essential for the operation of this model are listed in Table 1. In the case of steam application, assumptions were updated according to each specific case. The engine *KDI 1903M* was chosen for analysis, and its technical characteristics were used to obtain the modelling data. In the next stage, it is planned to use the given engine in experimental studies, thus validating the obtained theoretical data with steam application. This is a highly versatile 3-cylinder in line liquid cooled engine, used as an agricultural engine, as well as the engine for the generator set, compressor and pressure washer; the main specifications of it are listed in Table 2 [12].

Table 1

Initial conditions and assumptions for thermodynamic base model

Parameter	Value
<i>Initial conditions</i>	
Fuel	Diesel
Elements: (wt%)	
Carbon	86.6
Hydrogen	12.9
Oxygen	0.5
Lower heating value, MJ·kg ⁻¹	42.72
Air-fuel ratio	13
Initial temperature, K	288
Initial pressure, MPa	0.1
<i>Assumptions</i>	
Filling heating temperature, K	20
Heat utilization coefficient	0.7

Compared to the conventional compression ignition engine, steam is injected in the air intake manifold during the induction stroke. IMSI method was chosen as the most simplified option to achieve optimal results. Water injection would not give the desired results as the temperature of the intake manifold is much lower than that of water, which will not promote the conversion of water into steam.

Steam in-cylinder injection will be considered as a possible option in future studies if that particular method does not produce the desired results.

The model was previously validated in other researches [13], and corrections were made in it for the application of steam. It is known that water steam has the same chemical formula as water, but molecules in steam are not structured as it is in case of water in liquid and solid condition. Additionally, they have also different interaction between each other. Water steam contains two hydrogen and one oxygen molecule. It is assumed that the ratio of hydrogen and oxygen by mass in water is 1:8, which was considered during modelling.

Table 2

Basic engine parameters

Parameter	Value
Engine type	CI engine
Cylinders	3
Bore, mm	88
Stroke, mm	102
Compression ratio	17

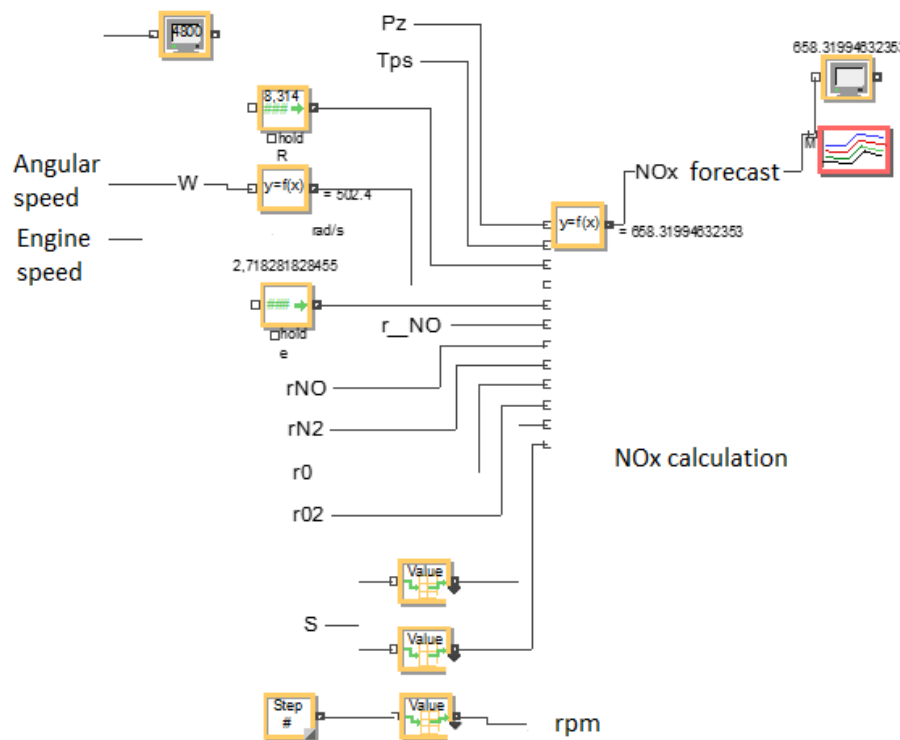

Fig. 1. Schematic of one module of the common thermodynamic model used in the research

Modelling was performed at the crankshaft speed (2600 rpm), when the engine must reach maximum power based on the manufacturer data. The impact of the steam injection mass on the expansion ratio, temperature, power, and NO_x were analysed. As a result of the model operation, it is assumed that steam was injected into the intake manifold at the time of the induction stroke at different steam injection mass: 10, 20, 30, 40 and 50 mg. This type of method was chosen as the exact dosing of the steam amount is expected also in the experimental studies.

Maximum allowable limit of water steam which can be injected into the engine was determined by mathematical expressions and was included in the model. The temperature when condensation begins below this limit was found using the following mathematical expression [9]:

$$T = \left[\frac{\dot{m}_{x,a}(c_p + 1.82)T_0 + \dot{m}_{x,a}(w_x - w_0)2500.9 + \dot{m}_s h_s}{\dot{m}_{x,a}(c_p + 1.82w_0)} \right], \quad (1)$$

where w_0 – specific humidity of the mixture, $\text{g}\cdot\text{kg}^{-1}$;
 w_x – specific humidity of atmospheric air, $\text{g}\cdot\text{kg}^{-1}$;
 c_p – specific heat of dry air, $\text{J}\cdot(\text{kg}\cdot\text{K})^{-1}$;
 T_0 – temperature of atmospheric air, K ;
 h_s – enthalpy of injected steam, J ;
 $\dot{m}_{x,a}$ – mass flow rate of atmospheric air, $\text{g}\cdot\text{s}^{-1}$;
 \dot{m}_s – mass flow rate of injected steam, $\text{g}\cdot\text{s}^{-1}$.

Results and discussion

The effect of the steam injection mass on the engine thermodynamic parameters was observed and analysed in this section. Fig. 2a shows the effects of the steam injection mass on the temperature at the end of compression and 2b shows the effects of the steam injection mass on the temperature at the end of combustion. It could be observed that the temperature at the end of compression increases with the amount of injected steam while the peak temperature decreases in such way providing easy ignition. In case of water injection longer ignition delay could be observed, which could be reduced with a well mixture preparation [9]. Therefore, increased amount of steam could promote this easy ignition option. Besides, combustion duration could be prolonged, and the flame speed decreased with increased amount of steam, which could be also confirmed by the steam impact on reduction of concentration of OH and H radicals [14]. Therefore, steam reduces high-density flame distribution and results in the temperature drop in the cylinder.

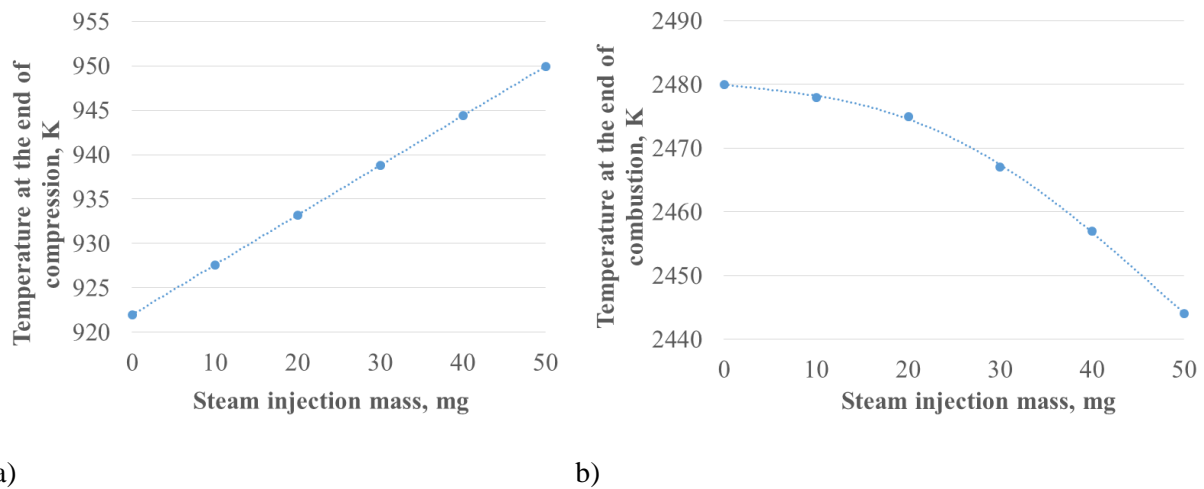

Fig. 2. Effect of steam mass on the temperature at the end of combustion (a) and the temperature at the end of combustion (b)

The impact of the steam injection mass on the pressure increase ratio is illustrated in Fig. 3a. It is observed that the steam injection mass increase improves also the in-cylinder pressure, which could be explained by improvement of the combustion process. Therefore, improvement in the pressure increase ratio is also observed, which must improve further also the engine power. As it is known, the maximum in-cylinder pressure is closely related to the fuel consumption and power performance.

Fig. 3b shows the engine effective power improvement based on the steam injection mass increase. Similar situation during modelling was also observed with the fuel specific consumption, although the data obtained are not reflected in this publication. However, such increase is lower, as it would be expected, for example, in case of in-cylinder steam injection, where the mass flow rate would be increased [8]. Besides, the maximum steam injection mass is limited based on the exhaust temperature and the heat exchange capability [8]. In any case increase in power, as also the torque, could be explained by the fact that steam injection contributes to decreased fuel droplet diameters and better atomization

[9]. Water droplets vaporize rapidly in such way absorbing the heat of the cylinder charge owing to the high heat capacity and partial pressure of oxygen increases [15].

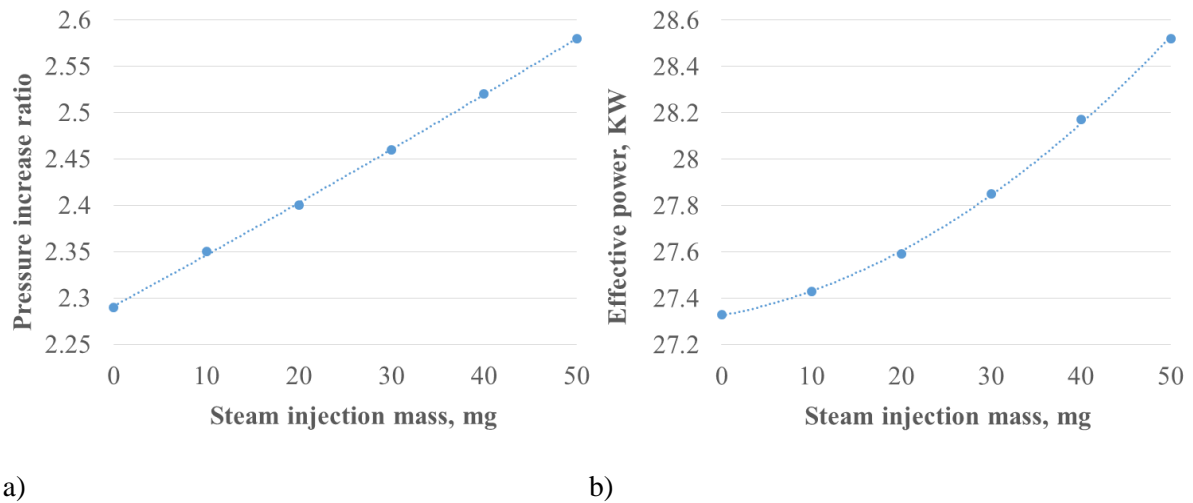

Fig. 3. Effect of steam mass on the pressure increase ratio (a) and effective power (b)

As it is known, NO_x formation is strongly dependent on many factors, the most important of which is high temperature in the cylinder during combustion or the peak combustion temperature. As it was seen in Fig. 2, as the combustion temperature decreases, then must be expected decrease also in NO_x emissions. Fig. 4 confirms this statement. Reduction could be explained by the combined effect of different factors – vaporization absorbing heat, high molar heat capacity of H_2O and reduced partial pressure of oxygen [9]. Therefore, it could be concluded that the specific heat of steam is more than 2 times higher than of the air. This allows to absorb more than 2 times higher heat allowing to reduce the peak combustion temperature during formation of oxides of nitrogen [9].

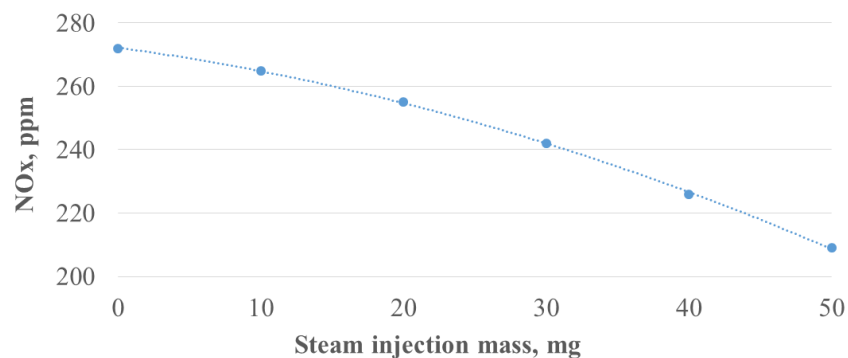

Fig. 4. Effect of steam mass on NO_x emissions

Increased steam injection effect could be usable in case of biofuels as the formation of the main combustion products, including NO , will be decreased and the specific heat together with the engine performance increased [15]. Utilization of oxygenated fuels, for example biodiesel, which produce larger NO_x emissions, together with steam injection would be a valuable solution. For example, Cesur [16] has found decrease in NO_x emissions by 13.7% and increase in the power by 2.2% using 15% steam injection to diesel fuel containing biodiesel (90% diesel + 10% biodiesel).

Conclusions

The use of steam in small quantities could be a suitable solution for increasing the engine efficiency and reducing emissions in diesel engines. The increase in the pressure and decrease in the combustion temperature in the cylinder can have both positive and negative benefits – combustion improvements, as also reduction of NO_x emissions. For example, at 50 mg of steam injection, the combustion temperature and NO_x emissions decreased by 36 K and 62 ppm, respectively. At the same time, a slight

increase in the power in the amount of 4.3% is observed due to a growth of the pressure increase ratio. As there is a possibility of the growth of other emissions than it is necessary to find the optimal method and quantity of supplied steam and possibly also fuel (for example, biodiesel) to obtain the best results. The created model confirms the relationships obtained theoretically and experimentally by other researchers, which indicates the possibility of its further application.

The next stage of the research will be focussed on the validation of the theoretical results by performing experimental studies of the particular engine on the engine test bench. Likewise, further research could pay attention also to the effect of the steam temperature, injection pressure, as also injection timing on the engine operating parameters.

Author contributions

Conceptualization, R.S., methodology, R.S. and A.B., software, K.A. and A.B., validation, R.S. and K.A.; formal analysis, K.A. and R.S., investigation, K.A., R.S., and A.B., writing – original draft preparation, K.A. and R.S., writing – review and editing, K.A. and R.S., visualization, K.A. All authors have read and agreed to the published version of the manuscript.

References

- [1] Smigins R. Perspectives of low level ethanol and biodiesel/diesel fuel blends on diesel engine emission reduction. In Proceedings of the 20th International Scientific Conference on Transport Means, Juodkrante, Lithuania, 5-7 October 2016; pp. 337-341.
- [2] Kryštopta S., Górski K., Longwic R., Smigins R., Kryštopta L., Matijošius J. Using Hydrogen Reactors to Improve the Diesel Engine Performance. *Energies*, 2022, 15, 3024. DOI: 10.3390/en15093024
- [3] Aydin K., Kenanoglu R. Effects of hydrogenation of fossil fuels with hydrogen and hydroxy gas on performance and emissions of internal combustion engines. *International Journal of Hydrogen Energy*, 2018, 4, 14047-14058. DOI: 10.1016/j.ijhydene.2018.04.026.
- [4] Khan M.B., Kazim A.H., Farooq M., Javed K., Shabbir A., Zahid R., et al. Impact of HHO gas enrichment and high purity biodiesel on the performance of a 315 cc diesel engine. *International Journal Hydrogen Energy*, 2021, 46, 19633-19644. DOI: 10.1016/J.IJHYDENE.2021.03.112.
- [5] Masjuki H.H., Ruhul A.M., Mustafi N.N., Kalam M.A., Arbab M.I., Rizwanul Fattah I.M. Study of production optimization and effect of hydroxyl gas on a CI engine performance and emission fueled with biodiesel blends. *International Journal of Hydrogen Energy*, 2016, 41, 14519-14528. DOI: 10.1016/j.ijhydene.2016.05.273
- [6] Lif A., Holmberg K. Water-in-diesel emulsions and related systems. *Advances in Colloid and Interface Science*, 2006, pp. 231-239. DOI: 10.1016/j.cis.2006.05.004
- [7] Zhao R., Zhang Z., Zhuge W., Zhang Y., Yin Y. Comparative study on different water/steam injection layouts for fuel reduction in a turbocompound diesel engine. *Energy Conversion and management*, 2018, pp. 1487-1501. DOI: 10.1016/j.enconman.2018.06.084
- [8] Zhang Z., Liu Q., Zhao R., Chen Y., Qin Q. Research on in-cylinder steam injection in a turbocompound diesel engine for fuel savings. *Energy*, 2022, 121799. DOI: 10.1016/j.energy.2021.121799
- [9] Parlak A. A study on performance and exhaust emissions of the steam injected DI diesel engine running with different diesel-conola oil methyl ester blends. *Journal of the Energy Institute*, 2019, 92(3), pp. 717-729. DOI: 10.1016/j.joei.2018.03.001
- [10] Gonca G. Investigation of the effects of steam injection on performance and NO emissions of a diesel engine running with ethanol–diesel blend. *Energy Conversion Management*, 2014, 77, pp. 450-457. DOI: 10.1016/j.enconman.2013.09.031
- [11] Wu J., Kang Z., Wu Z. Thermodynamic Analysis of In-Cylinder Steam Assist Technology within an Internal Combustion Engine. *Applied Sciences*, 2022, 12, 6818. DOI: 10.3390/app12136818
- [12] Diesel Kohler engine KDI model 1903M. [online] [03.03.2023]. Available at: <https://deltaservicedieselenines.com/en/51-kohler-engine-kdi-1903-m.html>
- [13] Dukulis I., Birkavs A. Development of model for running diesel engine on rapeseed oil fuel and its blends with fossil diesel fuel. In Proceedings of 12th International scientific conference “Engineering for rural development”, Jelgava, Latvia, May 23 - 24, 2013; pp. 319-325.

- [14] Xie YL., Wang JH., Xu N., Yu SB., Huang ZH. Comparative study on the effect of CO₂ and H₂O dilution on laminar burning characteristics of CO/H₂/air mixtures. *International Journal of Hydrogen Energy*, 2014, 39(7), pp. 3450-3458. DOI: 10.1016/j.ijhydene.2013.12.037
- [15] Gonca G. Investigation of the influences of steam injection on the equilibrium combustion products and thermodynamic properties of bio fuels (biodiesels and alcohols). *Fuel*, 2014, pp. 244-258. DOI: 10.1016/j.fuel.2014.12.032
- [16] Cesur I. Investigation of the effects of steam injection on the emissions and performance of a diesel engine using waste chicken oil methyl ester. *Journal of Mechanical Science and Technology*, 2016, 30, pp. 4773-4779. DOI: 10.1007/s12206-016-0949-0